



PRODUCT DATA SHEET

P/N: **1048-5**
TRIPLE QUART CAN MOUNT



The Aerosol Can Mounts are simple storage mounts providing a drop-in pocket for many items. The Triple Quart Can Mount holds 3 quart size cans and is perfect for quart size fuel and oil cans.

TYPICAL SPECIFICATION

FEATURES

- Chemical resistant material
- Lightweight and space saving
- High impact strength

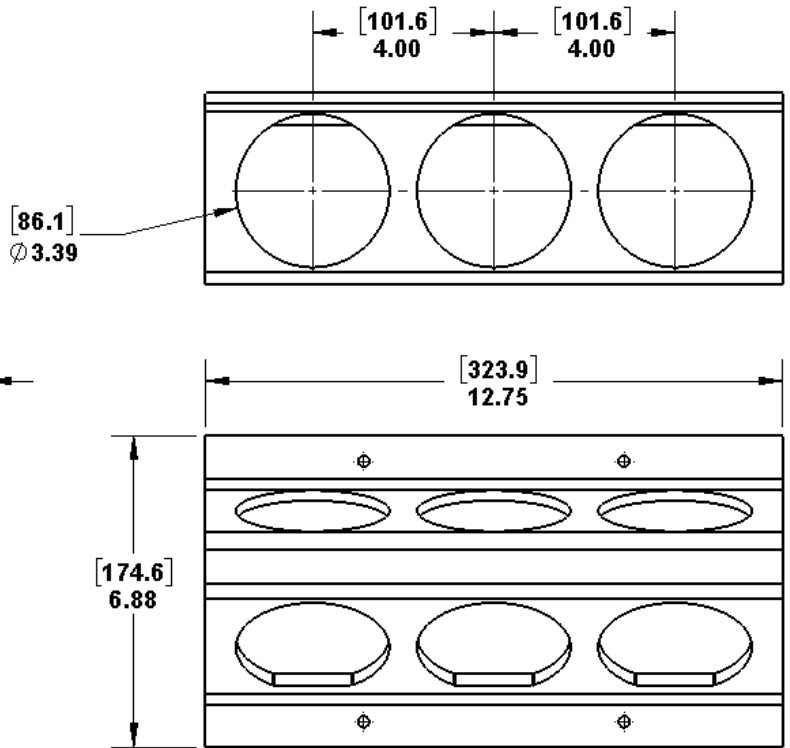

SPECIFICATIONS

P/N	WT.	MAX LOAD	GRIP RANGE	HANGER RANGE	FLAME TOXICITY CHEMICAL
1048-5	1lb	N/A	N/A	N/A	N/A

Dimensions: 12.75" L x 6.88" W x 4.22" H

Performance Advantage Company

Lancaster, New York

www.pactoolmounts.com

888-514-0083

REFERENCE	QTY	REMARKS	PROJECT
			LOCATION
			BUYER
			DEALER
			BUILDER
			SUBMITTED BY:
			DATE:



The Aerosol Can Mounts are simple storage mounts providing a drop-in pocket for many items. The Triple Quart Can Mount holds 3 quart size cans and is perfect for quart size fuel and oil cans.

- Chemical resistant material
- Lightweight and space saving
- High impact strength

