

REV	DESCRIPTION	DATE	APPR

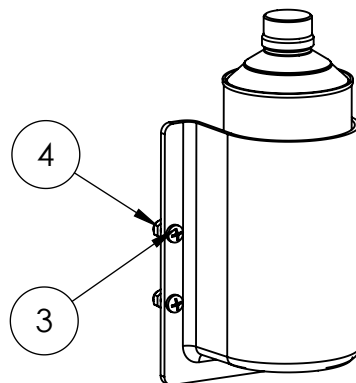

STD. MOUNTING

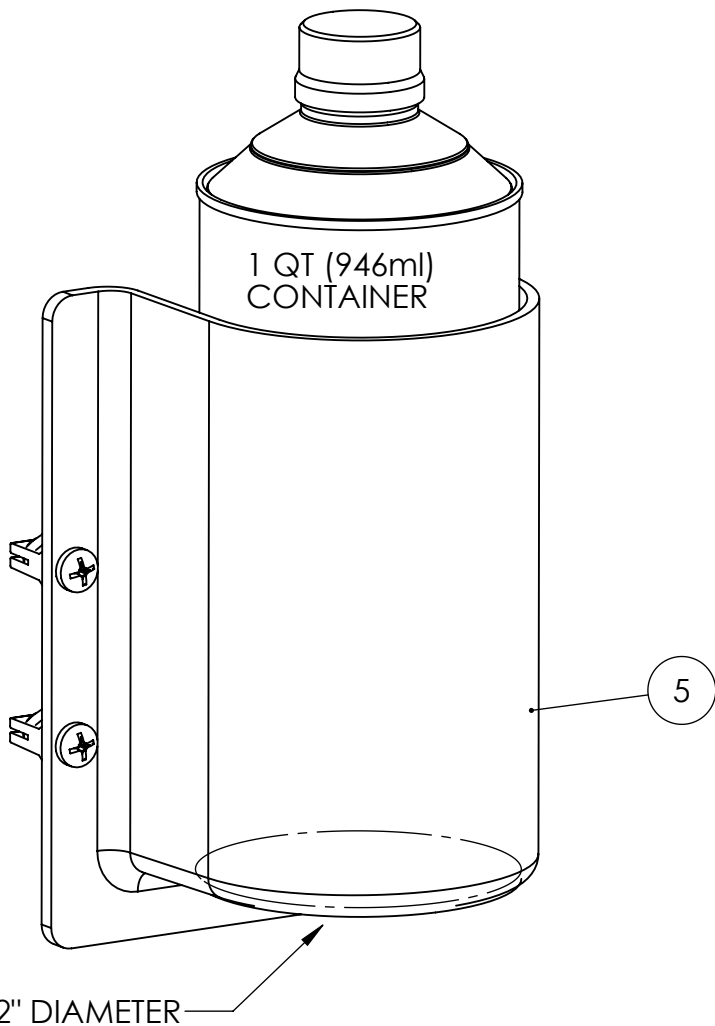
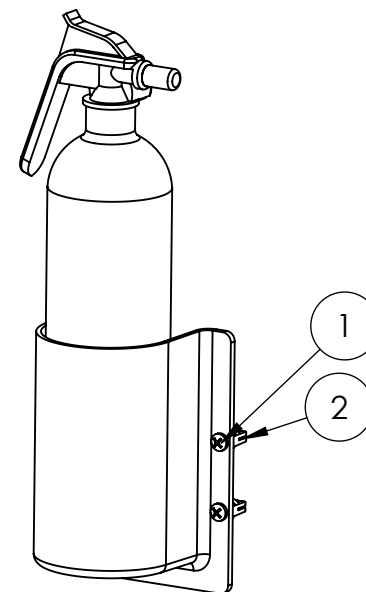

PAC TRAC MOUNTING

5	1044-3P	3-1/2" CYLINDER POCKET	1
4	2069LN	1/4-20 NYLON LOCK NUT	4
3	2098	14-20 X 34 PHIL PANHEAD	4
2	7016	TRAC LOK INSERT	4
1	2049	#10-24 X 3/4 PAN HEAD SCREW	4
ITEM NO.	PAC P/N	PART NAME	QTY.

TOLERANCES UNLESS OTHERWISE SPECIFIED

.X= ± .03
 .XX= ± .010
 .XXX= ± .005
 .XXXX= ± 0.0005
 ANGLES ± 0.5 °
 FRACTIONAL ± 1/64

THIRD ANGLE PROJECTION



COLOR

NAME DATE

DRAWN BY

APPR. BY

MFG BY

MFG. P/N

ENG APPR.

MATERIAL

ALT. MATERIAL

FINISH

THE INFORMATION CONTAINED IN THIS DRAWING IS THE SOLE PROPERTY OF PERFORMANCE ADVANTAGE CO. ANY REPRODUCTION IN PART OR AS A WHOLE WITHOUT THE WRITTEN PERMISSION OF PERFORMANCE ADVANTAGE CO. IS PROHIBITED.

TITLE:
 3-1/2" CYLINDER
 POCKET ASSEMBLY
 TALL

PART NUMBER
 1044-3

SCALE: 1:4

SHEET 1 OF 1

NOTES:

MAX DIAMETER : 3-1/2"

_____ LB (KG) CAPACITY

PAC TRAC COMPATIBLE

CHEMICAL RESISTANT MATERIAL

FLAME RETARDANT

PERFORMANCE
ADVANTAGE
COMPANY

