



24" VERTICAL SLIDE OUTS

P/N VSO-24

INSTALLATION INSTRUCTIONS

For additional assistance call (888)-514-0083 between 8AM-5PM EST or email: info@pactoolmounts.com

CAUTION

To avoid the risk of personal injury, property damage or product damage, please use the included fasteners for mounting.





- * This product must be securely mounted to a stable surface and material.
- * Misuse of this product may result damage or injury and void warranty.
- * Verify that all fasteners have been tightened securely before putting into service.
- * CAUTION: Cut edges of aluminum extrusions may be sharp. Use care when handling or assembly.

 Tool Board materials and hardware are determined by size and/or customer specifications and therefore must be ordered separately. Illustrations shown may not be representative of quantity or size for every application.

STEP 1 – Assemble Tool Board*

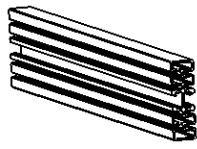
* Skip this step if you have received the tool board pre-assembled.

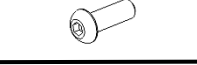
Align all sections of Double Face Dual Trac **P/N 7040** as shown. Position channel nuts **P/N 2023** into center grooves of board sections. Slide U-Channels **P/N 7009** over each end (*fit will be snug*). Attach the U-Channel with button head screws **P/N 2060**. Check that the board is square and even before securing. Do not over tighten.

Items Required for this step	Qty
 P/N 7040 Double Face Dual Trac	4 SECTIONS
 P/N 7009-4P U-Channel	2
 P/N 2060 1/4-20 x 3/4 B.H.C.S.	8
 P/N 2023 1/4-20 Channel Nut	8

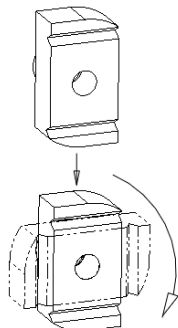

Push and Rotate
P/N 2023 Channel Nut

Figure 1 b

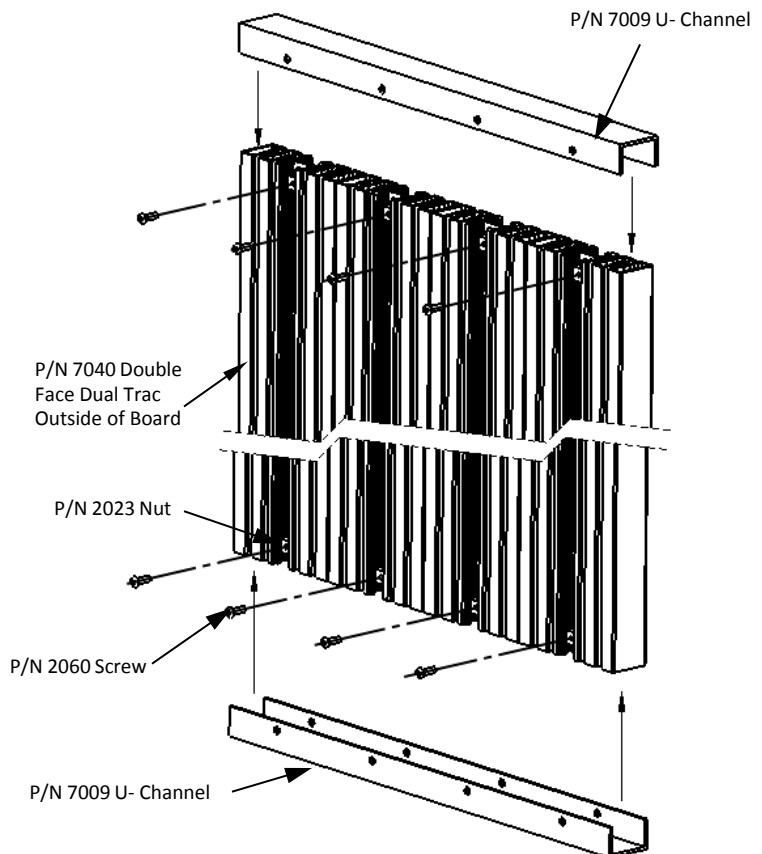







Figure 1a

STEP 2 – Attach Slide Assemblies to Tool Board



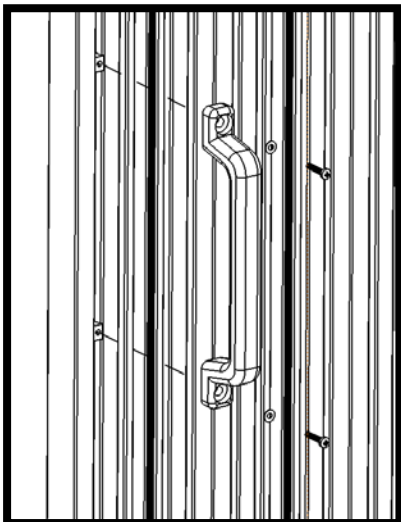
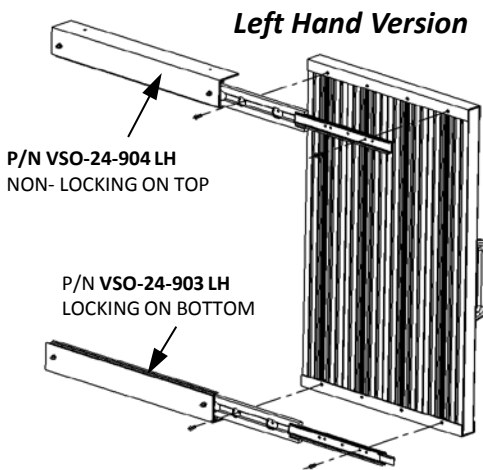
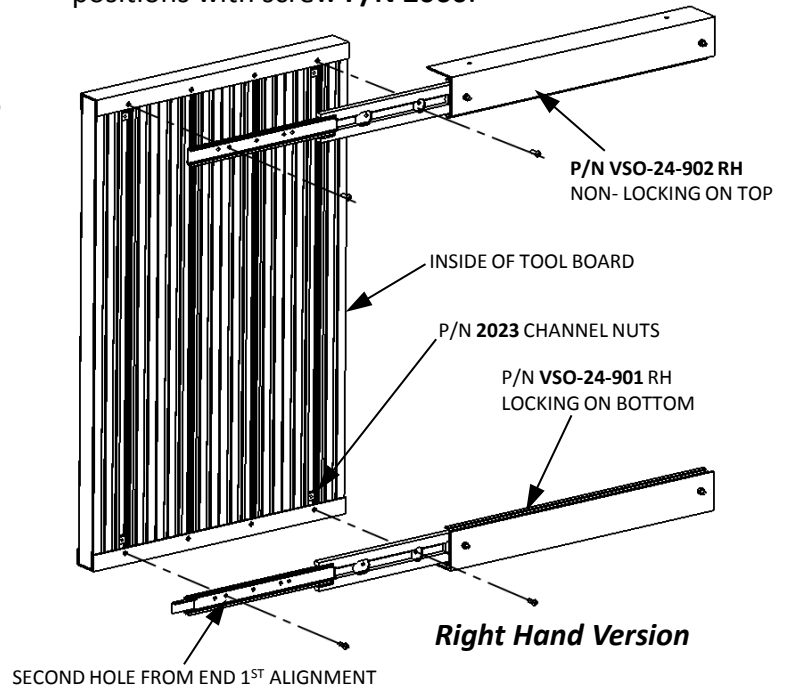

Items Required for this step	Qty
<i>RIGHT HAND VERSION</i>	
 P/N VSO-24-902 Pre-Assembled Slide Assembly RH Non-Locking	1
 P/N VSO-24-901 Pre-Assembled Slide Assembly RH Locking	1
 P/N 2023 1/4-20 Channel Nut	4
 P/N 2060 1/4-20 x 3/4 B.H.C.S.	4
<i>FOR LEFT HAND VERSION SUBSTITUTE P/N'S</i>	
 P/N VSO-24-904 Pre-Assembled Slide Assembly LH Non-Locking	1
 P/N VSO-24-903 Pre-Assembled Slide Assembly LH Locking	1

Insert Channel Nuts **P/N 2023** in the center groove of the outermost board sections.

Fully extend the pre-assembled slides to expose the mounting holes. The second hole from the end of the slide rail aligns with the channel nut in the first board section as shown. Fasten both positions with screw **P/N 2060**.



STEP 3 – Attach Handle

Items Required for this step	Qty
 P/N 4303-1 Grab Handle	1
 P/N 2046 #10-24 x 1" Pan Head Screw	2
 P/N 2011 Flat Washer	2
 P/N 7016 Trac Lok Insert	2

Place Trac Lok inserts **P/N 7016** into small groove in tool board at desired location. Use screw **P/N 2046** and washer **P/N 2011** to attach handle.

Do not over tighten. Can be placed on either side of tool board.

Attach Slideout direct to compartment floor and ceiling or use PMF Frame Assembly (see INS-PMF-VSO)