

REV	DESCRIPTION	DATE	APPR

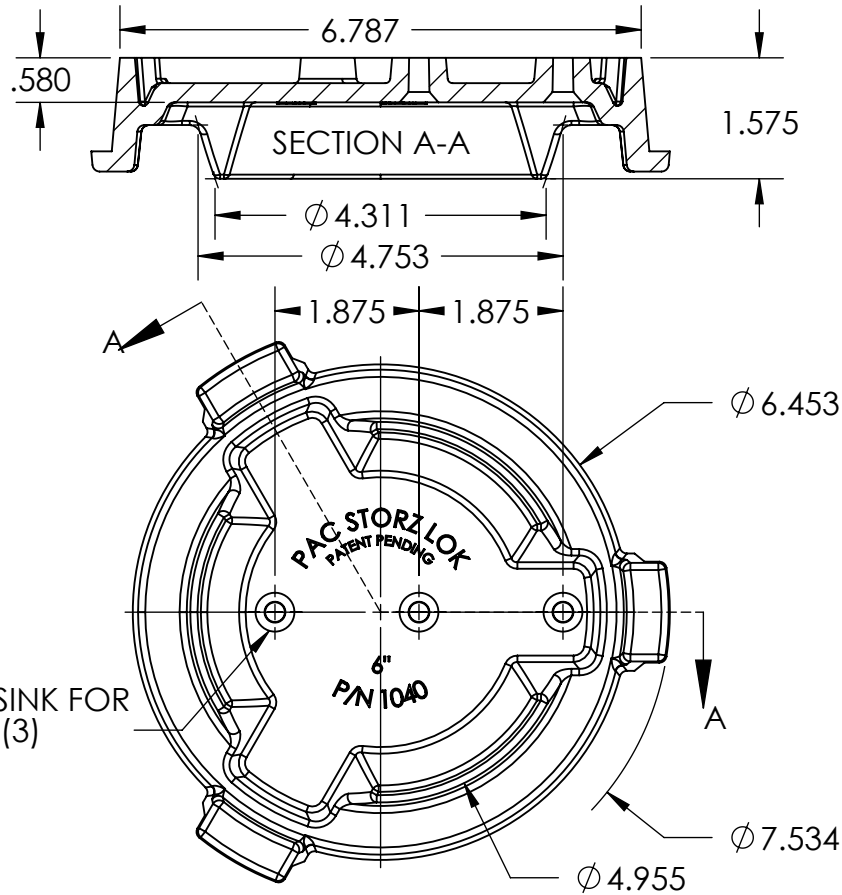

THRU & C'SINK FOR
1/4" F.H.S. (3)

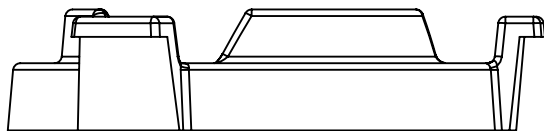
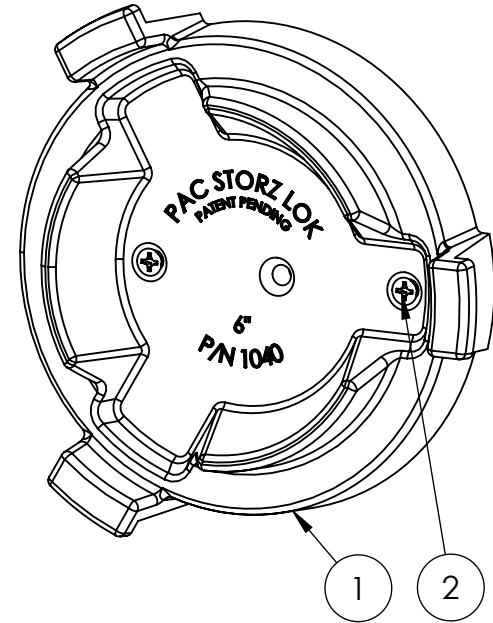

2	7031	FASTENER KIT	1
1	1040-6P	STORZ LOK 6"	1
ITEM NO.	PAC P/N	PART NAME	QTY

TOLERANCES UNLESS OTHERWISE SPECIFIED .X= ±.03 .XX= ±.010 .XXX= ±.005 .XXXX= ±0.0005 ANGLES ±0.5 ° FRACTIONAL ±1/64		NAME DATE	THE INFORMATION CONTAINED IN THIS DRAWING IS THE SOLE PROPERTY OF PERFORMANCE ADVANTAGE CO. ANY REPRODUCTION IN PART OR AS A WHOLE WITHOUT THE WRITTEN PERMISSION OF PERFORMANCE ADVANTAGE CO. IS PROHIBITED.
THIRD ANGLE PROJECTION 		DRAWN BY APPR. BY MFG BY MFG. P/N ENG APPR. MATERIAL	
COLOR		ALT. MATERIAL FINISH	TITLE: STORZ LOK 6" PART NUMBER 1040-6P
			REV SCALE: 1:2.5
			SHEET 1 OF 2

NOTES:

PERFORMANCE
ADVANTAGE
COMPANY

